

Command Post

The mission changes – so does BOXER



The Command Post variants of BOXER are the spearhead of command and control in theatre by acting as a centre for communication and control while being protected to a high level combined with superior mobility. Secured communication, displays for situation awareness in today's complex battlefield scenarios and instruments for network enabled warfare are key characteristics of this variant. In a first batch the German Army ordered 65 (called "FüFz") and the Dutch Army 55 BOXER vehicles in the Command Post variant.



In the configurations of the German and the Dutch Armies the vehicles provide a variety of radio transmitters for secured communication and data exchange. The Dutch configuration will be equipped with the latest C4I-architecture to be integral part of a new generation of vehicles. The German variant is enabled to fully support the IdZ-System (infantry soldier of the future) and will be equipped with a special display at the rear of the vehicle for briefing and to provide visual situation awareness to dismounted soldiers. Further on, it is equipped with a flexible seating arrangement, providing different seating positions for driving and stationary operation.



The increased demand for protection for Command Post vehicles against multiple threats in theatre is reflected in an integrated protection system already in the basic configuration of the Command Post, such as

- Mine protection (AT blast, AP)
- 360° ballistic protection up to 14.5 mm also at 30° elevation
- Protection against bomblets and artillery fragments

Mobility is not degraded with further up-armouring.



Command Post

Product data

Key figures

Maximum speed	103 km/h
Minimum speed	3 km/h
Engine capacity (ISO)	530 kW (720 hp)
Range	1,050 km
Max. straight gradient	60%
Max. slope gradient	30%
Trench crossing	2.0 m
Step climbing ability	0.8 m
Turning circle (skid steering)	15 m
Length	7.93 m
Width	2.99 m
Height (hull roof)	2.37 m
Ground clearance	0.50 m
Track	2.58 m
Protected volume	14 m ³

Characteristics

- Crew: 2+3 (1 driver, 1 commander, 1 military commander and 2 staff)
- 3 hatches for visual situation awareness
- Multifunctional 40" Display, also for briefing soldiers behind the opened rear ramp
- Air Condition and NBC-protection systems
- Fire extinguishing system (engine compartment)

Exemplary Options

- Navigation system
- Smoke-grenade launching system
- Rear view camera
- Fire extinguishing system (Mission Module)
- Different protection kits
- Remote controlled weapon station

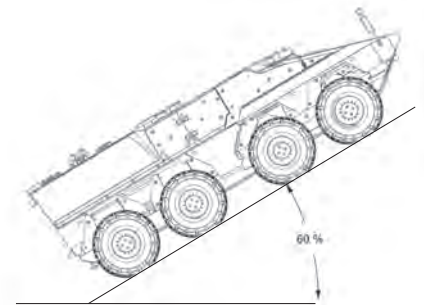
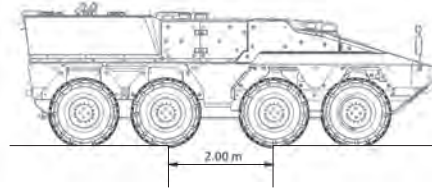
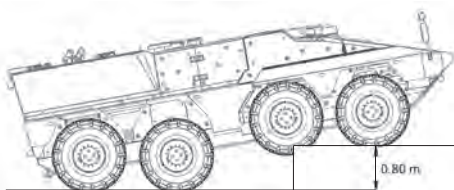

ARTEC

ARTEC GMBH

Krauss-Maffei-Strasse 11 · 80997 Munich · Germany
 Tel. +49 89 892130-0 · Fax +49 89 892130-17
 mail: info@artec-muc.de · www.artec-boxer.com

ARTEC GmbH is a joint venture of
 Krauss-Maffei Wegmann and Rheinmetall Landsysteme.