

Cargo/C2

The mission changes – so does BOXER



The Cargo/C2 variant of the BOXER is a multipurpose vehicle, which is derived from the Cargo version.

It can be used for several staff tasks within the armoured and infantry units. The Cargo/C2 has a prime role at the lowest level of command and control, but also provides a protected cargo carrying capacity. For this reason the vehicle has a dedicated but flexible interior. In a first batch the Dutch Army ordered 19 BOXER vehicles in the Cargo/C2 variant.



The BOXER Cargo/C2 interior has the flexibility to be reconfigured to suit three different functions:

- Command function – C2 function with seating for 3 extra passengers
- Cargo transport function – the rear part of the mission module floor can be used for one and half tonnes of cargo
- Casualty transport – additional possibility to transport a NATO stretcher and casualty

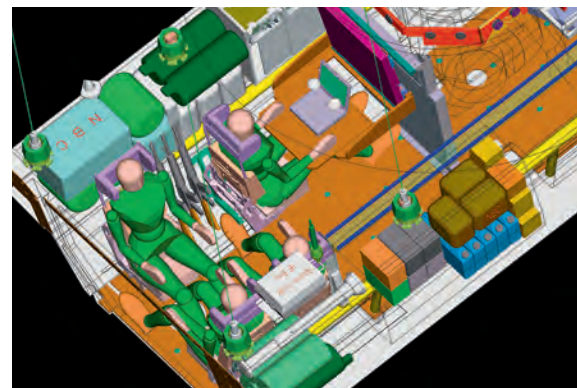

It has a standard crew of three: driver, commander and weapon operator.

Depending on the configuration the vehicle can also accommodate up to 4 passengers, a stretcher and casualty or one and half tonnes of cargo.



Cargo/C2

Product data

Key figures

Maximum speed	103 km/h
Minimum speed	3 km/h
Engine capacity (ISO)	530 kW (720 hp)
Range	1,050 km
Max. straight gradient	60%
Max. slope gradient	30%
Trench crossing	2.0 m
Step climbing ability	0.8 m
Turning circle (skid steering)	15 m
Length	7.93 m
Width	2.99 m
Height (hull roof)	2.37 m
Ground clearance	0.50 m
Track	2.58 m
Protected volume	14 m ³

Characteristics

- Crew: 3 (1 driver, 1 commander, 1 weapon operator)
- Capacity: 1 C2 operator, 3 passengers or 1,500 kg cargo
- Additional optronic sight system for commander
- Air Condition and NBC-protection systems
- Fire extinguishing system (engine compartment)

Exemplary Options

- Navigation system
- Smoke-grenade launching system
- Rear view camera
- Fire extinguishing system (Mission Module)
- Different protection kits
- Remote controlled weapon station

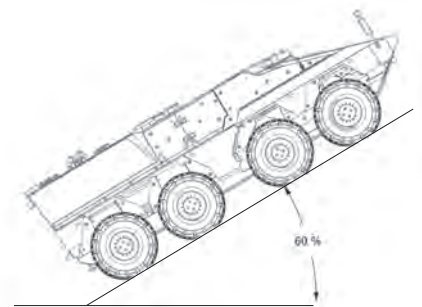
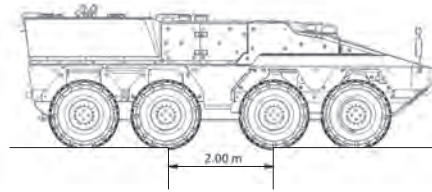
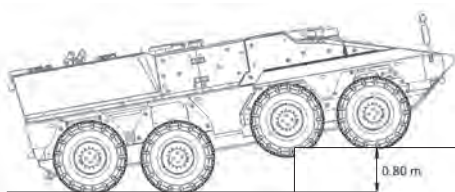

ARTEC

ARTEC GMBH

Krauss-Maffei-Strasse 11 · 80997 Munich · Germany
 Tel. +49 89 892130-0 · Fax +49 89 892130-17
 mail: info@artec-muc.de · www.artec-boxer.com

ARTEC GmbH is a joint venture of
 Krauss-Maffei Wegmann and Rheinmetall Landsysteme.

