

Battle Damage Repair

The mission changes – so does BOXER



To support the maximum availability of deployed vehicles and equipment the Battle Damage Repair variant of BOXER provides maintenance and diagnostic services on the battlefield, under protection and for a sustained period.

The vehicle and its crew can also execute logistic support tasks during combat operations to a range of land systems.

The Battle Damage Repair variant has a crew of four: driver, commander and two technicians.

This variant is also able to accommodate the special equipment, tools, expendable and non-expendable supplies needed to carry out diagnoses, maintenance and minor repairs if required.

By ensuring the availability of deployed vehicles and equipment, the Battle Damage Repair variant of the BOXER is of great value in safeguarding the crew and securing the success of any kind of military mission. As the vehicle is protected as any other BOXER variant, it can operate also in the front line, supporting combat vehicles.



Battle Damage Repair

Product data

Key figures

| | |
|--------------------------------|-------------------|
| Maximum speed | 103 km/h |
| Minimum speed | 3 km/h |
| Engine capacity (ISO) | 530 kW (720 hp) |
| Range | 1,050 km |
| Max. straight gradient | 60% |
| Max. slope gradient | 30% |
| Trench crossing | 2.0 m |
| Step climbing ability | 0.8 m |
| Turning circle (skid steering) | 15 m |
| Length | 7.93 m |
| Width | 2.99 m |
| Height (hull roof) | 2.37 m |
| Ground clearance | 0.50 m |
| Track | 2.58 m |
| Protected volume | 14 m ³ |

Characteristics

Crew: 4 (1 driver, 1 commander, 1 weapon operator/technician, 1 technician)
 Additional optronic sight system for commander
 Air Condition and NBC-protection systems
 Fire extinguishing system (engine compartment)

Exemplary Options

Navigation system
 Smoke-grenade launching system
 Rear view camera
 Fire extinguishing system (Mission Module)
 Different protection kits
 Remote controlled weapon station

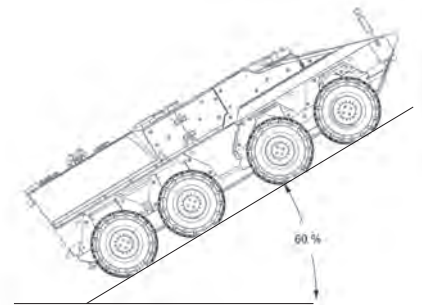
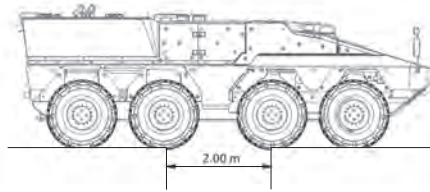
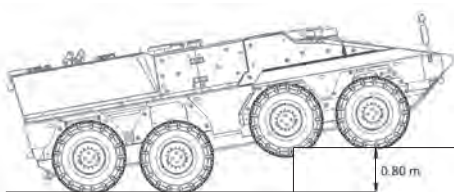

ARTEC

ARTEC GMBH

Krauss-Maffei-Strasse 11 · 80997 Munich · Germany
 Tel. +49 89 892130-0 · Fax +49 89 892130-17
 mail: info@artec-muc.de · www.artec-boxer.com

ARTEC GmbH is a joint venture of
 Krauss-Maffei Wegmann and Rheinmetall Landsysteme.